

MD-25 agitator series is a **convenient solution for compact installations**. Its **reversed ventilation system** adds an hanging installation to the standard one. The 115V 60Hz version available on demand.

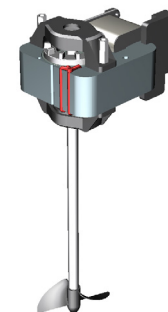

MD-25



TECHNICAL SPECIFICATIONS

Category	Classic AGITATOR.
Windings	Single-phase motor. Insulation Class F.
Motor body	Shaded poles motor.
Protection	IP 00 ingress protection rating.
Safety	Built-in thermal motor protection system.
Ball bearings	NSK and SKF (long-life) self-lubricant bearings or equivalent, in semi-rigid noise-damping housings.
Motor shaft	AISI 303 INOX steel.
Fastening parts	INOX steel or corrosion-resistant materials.
Motor parts	N.A.
Cooling system	Air cooled pump with a suction speed of 3,1 m/s.
Operation	Power supply 115 or 220-240 Volts - 24 hours a day non stop. Clean non drinkable water only.
Regulations	Check machine's requirements.
Note	Secure the motor at a min. distance from the water of 20 mm. Read the instruction booklet for correct set up and use.

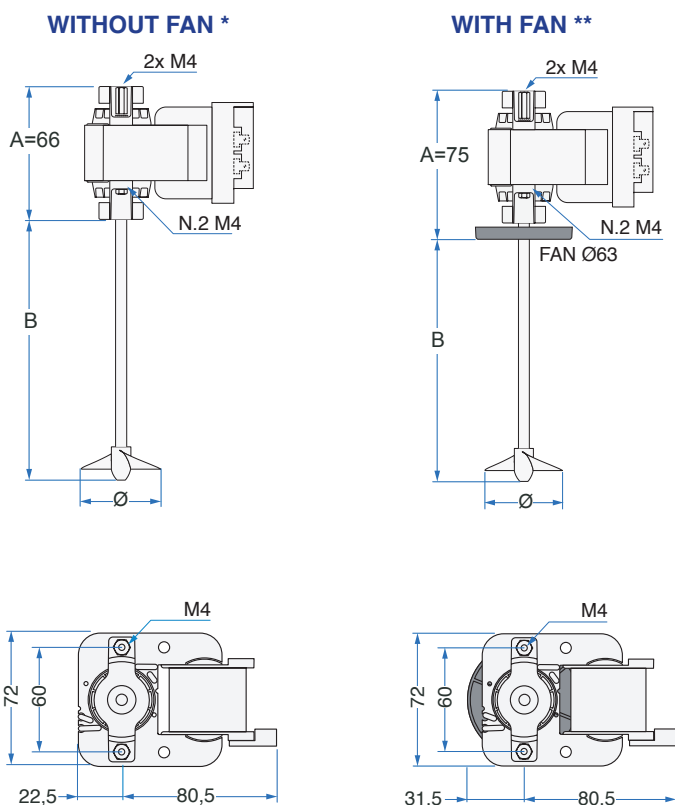

TYPE	Volt	Hz	Amp	Watt	RPM	A	B	Propeller Ø [mm]	Weight [Kg]
MD-25 *	220-240	50-60	0,40	40	2830-3300	66	173/225	45x30° 2 Blades	1,2
MD-25 *	220-240	50-60	0,40	40	2830-3300	66	173/225	50x15° 2 Blades	1,2
MD-25 *	220-240	50	0,43	45	2750	66	179/231	62x15° 2 Blades	1,2
MD-25 *	115	60	0,65	39	3240	66	173/225	50x15° 2 Blades	1,4
MD-25 **	220-240	50-60	0,40	40	2830-3300	75	164/216	45x30° 2 Blades	1,2
MD-25 **	220-240	50-60	0,40	40	2830-3300	75	164/216	50x15° 2 Blades	1,2
MD-25 **	220-240	50	0,43	45	2750	75	170/220	62x15° 2 Blades	1,2
MD-25 **	115	60	0,65	39	3240	75	164/210	50x15° 2 Blades	1,4

Rev. 21-02 Performance and electrical data have been tested at 20°C with clean water only. The company reserves the right to modify specifications without prior notice.
 © SABER SRL 2024 - ALL RIGHTS RESERVED - REGISTERED DESIGN - www.saberpumps.com